

Observations on the Mechanical Properties of Nickel Oxide Scales

I. A. MENZIES, K. N. STRAFFORD*

Corrosion Laboratories, Department of Chemical Engineering, University of Manchester Institute of Science and Technology, Manchester, 1, UK

Received 19 April 1967

The mechanical properties of NiO scales produced by the complete oxidation of high-purity (grade-1) Ni and commercial-purity (grade-A) Ni have been investigated at 700 to 1000° C. The modulus of elasticity of both grades of oxide decreased with increasing temperature, whereas the modulus of rupture for grade-A oxide exhibited a maximum at 850° C and that for grade-1 oxide decreased with increasing temperature. At 700° C, elastic deformation to fracture occurred with both oxides, whereas, at temperatures $\geq 850^\circ\text{C}$, plasticity was also observed. The plasticity of grade-1 oxide was ~ 3 times greater than that of grade-A oxide.

Creep behaviour of the oxides was studied at 900 and 1000° C. Primary and secondary creep was observed and, in both oxides, the creep rates increased with increasing temperature and load. The creep rate of grade-1 oxide was 10 to 20 times greater than that for grade-A oxide.

1. Introduction

In comparison with the field of bulk oxides, current knowledge concerning the mechanical properties of oxide scales on metals is fragmentary. Most of the work so far has been concerned with the measurement of the strengths of copper oxides [1] and iron oxides [2-7]; although some, simple, creep experiments [8] have been performed on iron oxides. There is also some evidence that NiO [2-9], ZrO₂ [10], and Nb₂O₅ [11] possess some plasticity. Tensile tests [2] on NiO wires formed by high-temperature oxidation of Ni failed to indicate any significant ductility in NiO; although Sartell and Li [9] have shown that NiO in the form of a dendritic single platelet, 10 μm thick, could be bent at room temperature. Since NiO normally crystallises with a simple NaCl-type structure, it might be expected to exhibit plasticity. Transverse test methods (i.e. beam deflection) do not require specimens to be held in grips and obviate the use for attachment of conventional extensometer devices to specimens. This was, therefore, selected as the simplest method of

testing NiO coupons prepared by high-temperature oxidation of the metal.

2. Experimental

2.1. The Preparation of NiO Coupons by Thermal Oxidation of Metallic Ni

Two grades of Ni which differed in purity were used. Grade-A Ni was supplied as 0.006 in. thick sheet (1 in. = 25.4 mm) by Hopkins and Williams Ltd.† The impurities in this material were as follows (wt %): Co trace; Fe < 0.25; C < 0.6; Si < 0.07; Cu < 0.20; Mn < 0.25; Mg < 0.15; S < 0.01. The grade-1 Ni was supplied as 0.006 in. sheet by Johnson Matthey & Co Ltd‡, and contained the following impurities (ppm): Al, 1; Ca < 1; Cu, 3; Fe < 20; Mg < 1; Si, 2; Ag < 1.

NiO specimens were prepared by the complete oxidation of Ni coupons, ~ 3 cm long \times 0.3 cm wide, in air for 160 h at 1050° C. The metal coupons were degreased in trichlorethylene prior to oxidation. Preliminary experiments indicated that grade-1 specimens "curled-up" on oxidation; it was found necessary to suspend

*Present address: Department of Metallurgy, The University, Liverpool, UK.

†Chadwell Heath, Essex, UK.

‡Hatton Garden, London, EC1, UK.

a 5 g weight on such specimens in order to produce straight NiO coupons.

2.2. Transverse Test Apparatus

The essential features of the apparatus are shown in fig. 1. The oxide specimens were deformed at elevated temperatures using a centre-point loading technique. The load was applied to the specimen via an Al_2O_3 rod (4 mm diameter), which was supported in a vertical position by an Al_2O_3 guide-tube. The end of the loading rod was ground to a 60° knife-edge. The oxide coupon was supported on the narrow walls (0.15 cm thick) of an Al_2O_3 tray whose dimensions were $2.5 \times 1.5 \times 0.5$ cm. The oxide-coupon-supporting tray was placed on a rigid " Al_2O_3 table", such that the oxide coupon was centrally positioned within the hot furnace zone.

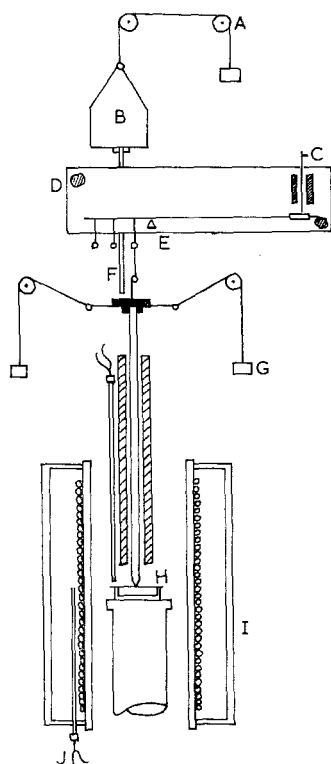

Figure 1 Major features of the transverse test apparatus: A, counterbalance; B, polythene loading receptacle; C, counterbalance; D, deflector; E, fulcrum; F, loading head; G, counterbalance; H, NiO specimen on Al_2O_3 tray; I, furnace; J, control thermocouple.

The loading head and simple deflector unit were built onto the Al_2O_3 loading rod

as shown in fig. 2. The deflector unit was constructed from 0.062 in. diameter brazing rod and a brass plate which was anchored rigidly to the apparatus framework. The entire system (i.e. Al_2O_3 loading rod and deflector lever arm) was counterbalanced as shown in figs. 1 and 2. The deflector lever was designed to give specimen deflection magnification of 5, 10, and 20 times. This deflection was measured by following the fiducial mark on the deflector with the microscope of a cathetometer. The reproducibility of this measuring instrument was ± 0.005 cm, and the maximum sensitivity of the deflector unit was ± 0.003 cm.

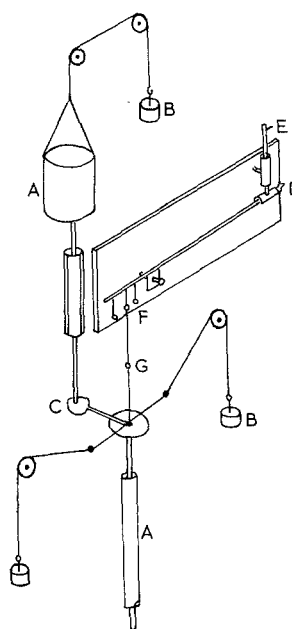

Figure 2 The deflector unit: A, Al_2O_3 guide-tubes; B, counterbalance weights; C, loading table; D, brass guide-tube and sliding bearing; E, fiducial mark; F, brass nut and bolt pivot; G, brass connecting rods.

In operation, the oxide coupon was placed in position and the Al_2O_3 loading rod was lowered so that it came to rest centrally on the oxide coupon. A positive load of 5 g applied to the loading rod prevented any specimen movement as the furnace was lowered into position. The oxide coupon was then heated to the desired temperature; extraneous heat transfer to the loading head was minimised by means of an asbestos radiation shield. On attaining the desired temperature, the Al_2O_3 system was allowed to stabilise until expansion was com-

plete. In the case of deformation experiments involving time-independent functions, a steadily increasing load was applied. This was carried out by the addition of 5 ml H_2O , every other minute, to a counterbalanced receptacle which rested upon the loading head of the Al_2O_3 loading rod. The movement of the fiducial mark on the deflectometer was recorded every alternate minute between the load increments. A load/deflection function was thus obtained, from which the strength and elastic properties were calculated. In creep experiments, a constant load was winched carefully onto the loading head, and the specimen deflection was recorded as a function of time.

3. Results

3.1. The Behaviour of NiO Coupons under Conditions of Increasing Load

Load/deflection data were obtained for both types of oxide under conditions of increasing load to fracture, or until the deflection was so great that it could not be accommodated with the deflectometer. The beam deflections as a function of applied load are given in figs. 3, 4, and 5, for 700, 850, and 1000°C, respectively. Several major features are clear from figs. 3 to 5.

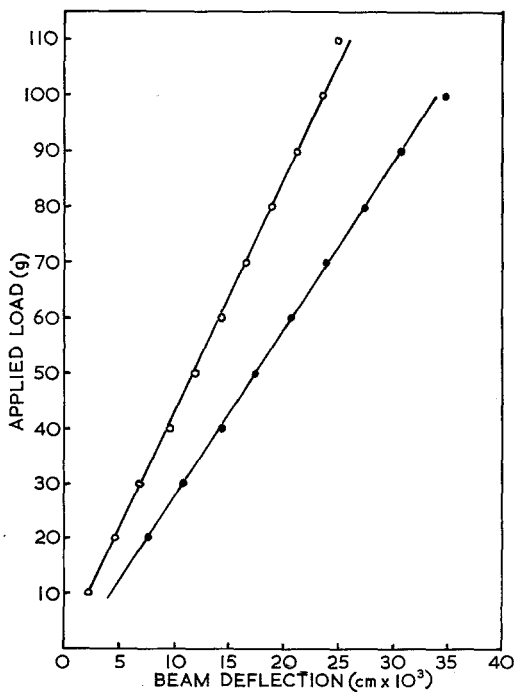

Figure 3 Deflection of NiO beams as a function of load at 700°C (O - grade-A NiO; ● - pure NiO).

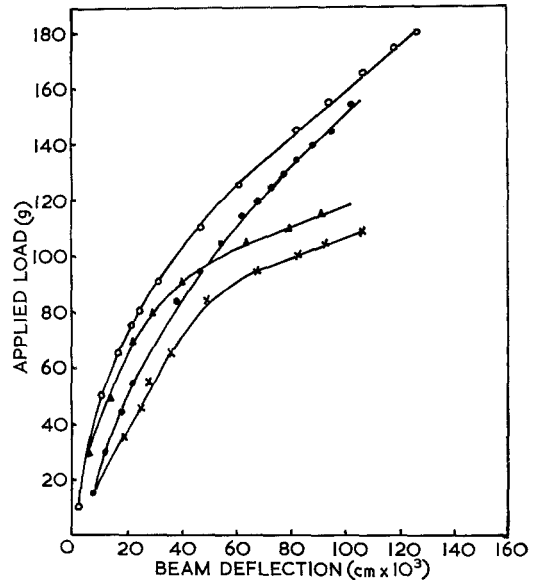

Figure 4 Deflection of NiO beams as a function of load at 850°C (O and ● - grade-A NiO; ▲ and × - pure NiO).

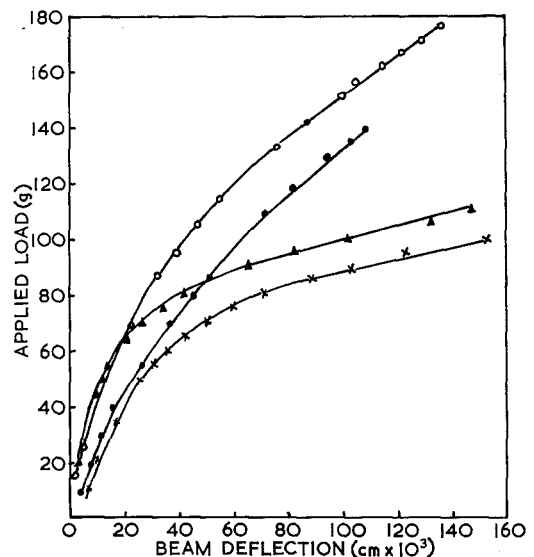

Figure 5 Deflection of NiO beams as a function of load at 1000°C (symbols as in fig. 4).

- (a) At 700°C, both oxides obeyed Hooke's law to fracture and there was no plastic deformation.
 (b) At 850 and 1000°C, the extension was a linear function of load for low loads and, after a critical load, plastic deformation was observed.
 (c) Plastic flow was always more extensive with the high-purity oxide and, at corresponding loads, was greater at 1000°C than at 850°C.

There was some scatter in the absolute

values of the deflection at which departure from Hooke's law became evident at 850 and 1000° C. At both temperatures, the best value was 30×10^{-3} cm, and the yield loads (P_y) used in the analyses have been taken as the loads corresponding to a deflection of 30×10^{-3} cm.

3.1.1. Modulus of Elasticity

It can be shown [12] that, for centre-point loading, the elasticity (E) of the beam is given by:

$$E = \frac{PL^3}{4bd^3y} \quad (1)$$

where: P is the load; L , the coupon length between its supports; b and d , the coupon widths; y , the deflection. The thickness of the oxide coupons (d) was taken from metallographic measurements as 0.028 cm. The load/deflection relationships were plotted for all three temperatures (cf. typical example in fig. 3), and the values of Young's modulus were obtained (table I). Clearly, Young's modulus decreased with increasing temperature from 700 to 1000° C for both oxides. The scatter in the results is such that no firm conclusions can be drawn concerning differences in modulus between the two oxides at corresponding temperatures.

3.1.2. Yield Strength and Modulus of Rupture

For centre-point loading, it can be shown that the yield strength (S_y) is given by:

$$S_y = \frac{3P_yL}{2bd^2} \quad (2)$$

where P_y is the yield load and the other symbols are as in equation 1. The calculated values of the yield strength at 850 and 1000° C are also given in table I.

The ultimate strength in bending cannot be determined from equation 2 by substituting the ultimate load (P_u) in place of the yield load (P_y), because equation 2 assumes Hooke's law to hold. For comparative purposes, however, an ultimate strength value, called the modulus of rupture, can be obtained by using the ultimate load (P_u) in equation 2. The calculated values of the modulus of rupture and the corresponding ultimate loads are also shown in table I. It is clear that the modulus of rupture had a maximum value at 850° C for commercial grade-A oxide, whereas this was not observed for high-purity NiO. Since the overall error in the absolute values for the modulus of rupture was $\pm 10\%$, it is not clear that there was any significant difference in the values at 700° C. However, it seems possible, from the results at 850 and 1000° C, that the strength of the impure grade-A NiO is somewhat greater than that of high-purity NiO.

It is also clear from these results that the plasticity of high-purity NiO is greater than that of impure grade-A (figs. 4 and 5). This suggested that a marked difference in the creep properties of the two oxides might be expected.

3.2. The Behaviour of NiO Coupons under Conditions of Constant Load

Since the data given above indicated that plasticity was becoming significant at 850° C, tests were carried out at 900 and 1000° C with both types of oxide with constant applied loads of 60 and 100 g. The smaller load was within the range for elastic behaviour and the larger in the range where plastic flow was observed.

The results of these experiments are summarised in figs. 6 and 7, where the behaviour of

TABLE I The mechanical properties of NiO (mean values).

| Grade NiO | Temperature (°C) | Average load to produce deflection of 30×10^{-3} cm (g) | Average breaking load (g) | Yield strength (lb/in. ² † $\times 10^{-3}$) | *Modulus of elasticity (lb/in. ² † $\times 10^{-6}$) | *Modulus of rupture (lb/in. ² † $\times 10^{-3}$) |
|-----------|------------------|--|---------------------------|--|--|---|
| 1 | 700 | 86 | 123 | — | 25.4 | 27.7 |
| 1 | 850 | 71 | 117 | 16.1 | 19.4 | 26.2 |
| 1 | 1000 | 60 | 100 | 13.6 | 16.1 | 22.4 |
| A | 700 | 132 | 132 | — | 35.4 | 29.5 |
| A | 850 | 80 | 160 | 18.1 | 25.4 | 36.2 |
| A | 1000 | 69 | 145 | 15.6 | 16.1 | 32.4 |

*The accuracy of these values is within $\pm 15\%$ for the modulus of elasticity and $\pm 10\%$ for the modulus of rupture.

†1 lb/in.² = 7×10^{-2} kg/cm².

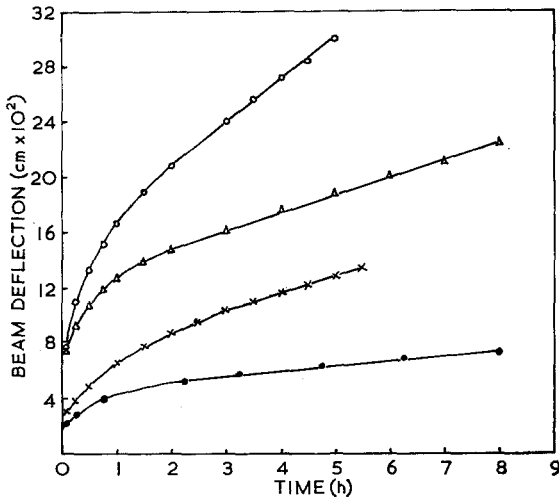

Figure 6 Deflection of grade-1 NiO beams as a function of time at constant load (O - 100 g, 1000° C; Δ - 100 g, 900° C; \times - 60 g, 1000° C; \bullet - 60 g, 900° C).

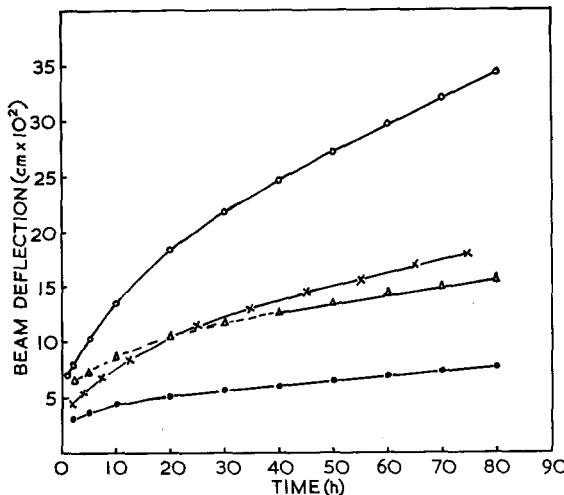

Figure 7 Deflection of grade-A NiO beams as a function of time at constant load (symbols as in fig. 6).

high-purity grade-1 NiO and low-purity grade-A NiO respectively is shown. Although there was some degree of scatter, the relative behaviour for both materials was clear. At both temperatures and for both oxides, there was initially a rapid rate of deflection; this was subsequently replaced by a second stage in which the deflection was an approximately linear function of time. Thus, both primary and secondary creep were well established. Furthermore, for each oxide, both rates of deformation increased with increasing temperature and applied load. The linear creep rates were calculated and the results are shown in table II. Analysis of

TABLE II Secondary creep rates for NiO beams.

| Grade NiO | Temperature (°C) | Creep rate (cm/h $\times 10^2$) | |
|-----------|------------------|----------------------------------|------------------|
| | | 60 g load | 100 g load |
| 1 | 900 | 0.3 \pm 0.01 | 1.3 \pm 0.03 |
| 1 | 1000 | 1.2 \pm 0.1 | 3.0 \pm 0.06 |
| A | 900 | 0.045 \pm 0.002 | 0.066 \pm 0.01 |
| A | 1000 | 0.11 \pm 0.05 | 0.23 \pm 0.03 |

the data in this table indicates that the creep rate of the high-purity oxide was consistently greater than that of grade-A oxide. For a 60 g load, the creep rate of the high-purity material was greater than that of the low-purity oxide by a factor of 7 to 10 at 900 and 1000° C; at 100 g load, this factor was even larger, being ~ 20 at 900° C and ~ 13 at 1000° C.

4. Discussion

The finite difference between the moduli of elasticity of the grade-A and grade-1 NiO is almost negligible at 700 to 1000° C. The modulus of elasticity of sintered polycrystalline NiO (99.9% pure) has been found [13] to decrease linearly with increasing temperatures in the range 700 to 1000° C. The absolute values were 17×10^6 to 19×10^6 lb/in.² ($1 \text{ lb/in.}^2 = 7 \times 10^{-2} \text{ kg/cm}^2$) at 700° C and 15.5×10^6 to 17.5×10^6 lb/in.² at 1000° C, compared with $\sim 30 \times 10^6$ lb/in.² at 700° C and $\sim 16 \times 10^6$ lb/in.² at 1000° C in the present work. The difference in absolute values is probably due to the different techniques used for oxide specimen preparation.

The most significant observation in the present work is the ability of NiO to undergo plastic deformation at temperatures $\geq 850^\circ \text{C}$. Tylecote [2] found that NiO was brittle (i.e. without elastic or plastic deformation) at 500 to 1150° C. This apparent anomaly in deformation behaviour of NiO at elevated temperatures may arise from differences in measurement technique. The tensile method used by Tylecote is not as favourable as the bending method, with respect to stress distribution, for revealing ductility. The fact that NiO does show ductility has been substantiated by Sartell and Li [9], who successfully deformed single dendrites of NiO at ambient temperatures. The present work has shown that the degree of plasticity is dependent upon the purity of the NiO. This may also be related to structure and grain size.

The strength of grade-A NiO exhibited a maximum at 850° C, and it is interesting to note

that Tylecote [2] observed a well-established maximum in the tensile strength of NiO, prepared from Ni of similar purity to grade-A Ni, at $\sim 900^\circ\text{C}$. The strengths of the NiO wires obtained by Tylecote ranged from 8×10^3 lb/in.² at 700°C to 6.5×10^3 lb/in.² at 1100°C . These results were, however, obtained under fast loading conditions (10 sec to fracture). Under tensile conditions, this might be expected to produce considerable scatter, and this was observed (100%). In the present work, the tests were carried out over a much longer period of time, with much less scatter, and therefore probably gave more reliable values.

The shape of the creep curves (figs. 6 and 7) indicates that an instantaneous extension of the NiO occurs. This represents work-hardening of the oxide up to some level which is dependent upon the applied stress. Primary creep then occurs, together with further work-hardening. The oxide flow stress then becomes greater than the applied stress, and thermal activation is required to produce further deformation. Some recovery will also occur during this period. The final stage of creep observed in the present work was secondary or steady-state creep. During this period, the work-hardening rate is balanced by recovery. It is clear that pure NiO (grade 1) has a much higher creep rate than grade-A NiO. This suggests that the presence of impurities is important, and it seems possible that creep in this material may be controlled by the interaction of dislocations with impurities. Since all of the present work has been carried out at temperatures $\leq 0.5 T_m$ (T_m for NiO is 1960°C), it is unlikely that creep is controlled by diffusion mechanisms which normally operate

at temperatures $> 0.5 T_m$. Clearly, much more experimental information concerning grain structure and activation energies is required before useful comments concerning creep mechanisms can be made.

Much more information concerning grain structure of the oxide coupons is required. Metallographic preparation of NiO coupons proved to be extremely difficult and, in almost all cases, some material was removed during polishing. Typical cross-section of the oxides are shown in fig. 8. The coupons of both oxides exhibited duplex structures with an outer layer of large columnar grains and an inner zone of fine-grained material. The inner zone was thickest in the specimen of grade-A oxide, which suggested that the presence of impurities had considerably hindered the growth of large columnar grains. The oxide densities were 90 to 95% of theoretical, and the apparent porosity in the grade-A specimen is due to the pull-out of the small grains in the centre.

Clearly, the absolute values of the modulus of elasticity and creep rates will seriously depend upon grain size, porosity, and probably thickness of the oxide scale. These factors are now being examined [14] in detail. It is also necessary to consider the development of new techniques for the measurement of mechanical properties of films which are growing and which are attached to the metal, in order to estimate the effect of ionic flux and other interfacial effects. Bradhurst and Leach [15-17] have recently shown that the effect of the presence of an ionic flux has a considerable effect upon the mechanical properties of growing, anodic oxide films on Al. It is, however, necessary to demonstrate

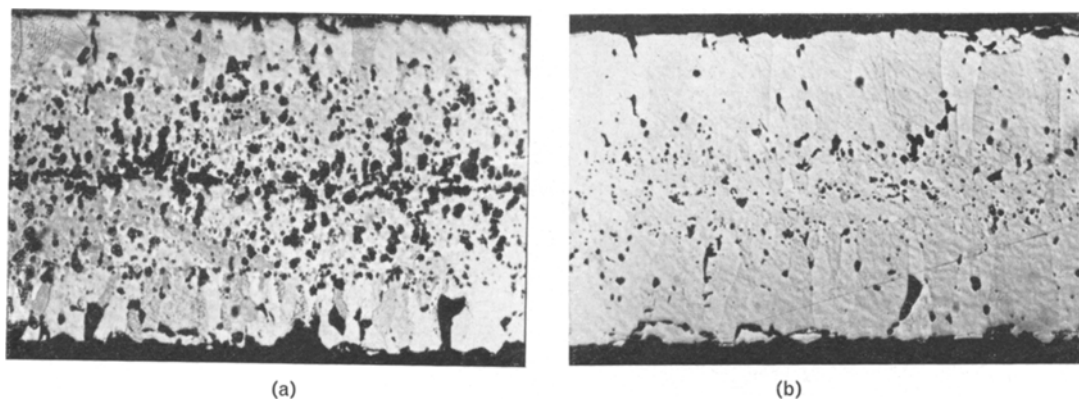

Figure 8 Cross-sections of NiO coupons obtained by total oxidation of Ni for 160 h at 1050°C : (a) grade-A NiO; (b) grade-1 NiO (unetched, $\times 157$).

that this is also the case with growing, thermally formed films. This is a much more difficult problem, since it is hard to control film growth and to produce films relatively free from porosity, regions of irregular growth, and other defects normally encountered in such films. Clearly, much more attention must be given to such studies.

Acknowledgements

We wish to thank Professor T. K. Ross for the provision of research facilities. One of us (K.N.S.) wishes to thank the University of Manchester for the award of a Turner and Newall Fellowship.

References

1. R. F. TYLECOTE, *J. Inst. Metals* **78** (1950) 301.
2. *Idem*, *J. Iron Steel Inst.* **196** (1960) 135.
3. G. VAGNARD and J. MANENC, *Mem. Sci. Rev. Met.* **62** (1965) 251.
4. *Idem*, *ibid* **60** (1963) 625.
5. *Idem*, *Compt. Mond.* **255** (1962) 104.
6. *Idem*, *ibid* **254** (1962) 1083.
7. G. VAGNARD *et al*, *ibid* **256** (1963) 5316.
8. J. D. MACKENZIE and C. E. BIRCHENALL, *Corrosion* **13** (1957) 783.
9. J. A. SARTELL and C. H. LI, "Mechanical Properties of Engineering Ceramics", edited by W. W. Kriegel and H. Palmour (Interscience, New York, 1961), p. 105.
10. D. L. DOUGLAS, *Corr. Sci.* **5** (1965) 255.
11. J. MARKALI, *op. cit.* ref. 9, p. 93.
12. A. C. HARIN and A. F. SAUER, "Strength of Materials" (Macmillan, London, 1958).
13. R. J. HERBOT, Ph.D. thesis, University of Illinois (1963).
14. I. A. MENZIES and P. ALDRED, unpublished work.
15. D. H. BRADHURST and J. S. L. LEACH, *Trans. Brit. Ceram. Soc.* **62** (1963) 793.
16. *Idem*, *J. Electrochem. Soc.* **110** (1963) 1289.
17. *Idem*, *ibid* **113** (1966) 1245.